

WSM22 - Magnetic shaft encoder

Based on Dipole Magnet and Hall Sensors

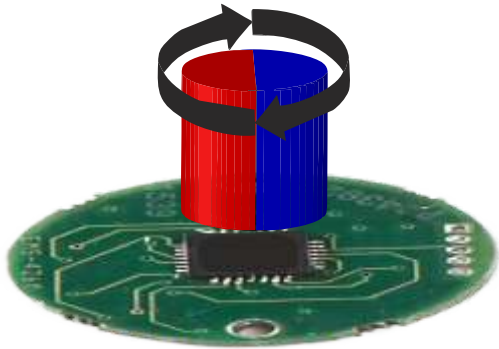

WSM22 magnetic encoder module consists of an encoder body and a magnet holder. The magnet holder is fitted on the rotating shaft and the encoder body in front of the magnet holder. The sensor inside the body will sense the rotating magnet and gives the Absolute as well as incremental outputs up to 14 bits per rotation.

This gives a very high speed, IP68 robust, bearing less encoder design ideally suitable for applications in harsh environments .

Salient Features:

- ☞ 22mm modular encoder with magnet holder
- ☞ Operates on 5V power supply
- ☞ Variety of outputs supported like Analog Sin-Cos output, Incremental RS422, Absolute SSI and BiSS-C protocol
- ☞ Supports up to 14 bits (16384 positions) per rotation Absolute and Incremental outputs
- ☞ Accuracy +/- 0.5 deg
- ☞ High Speed operation up to 20000 rpm at finest resolution
- ☞ 3600 CPR also available to give angular resolutions easier for mathematical calculations
- ☞ Suitable for applications like motor control, Medical instrumentation, paper and textile industry, Industrial automation and many more

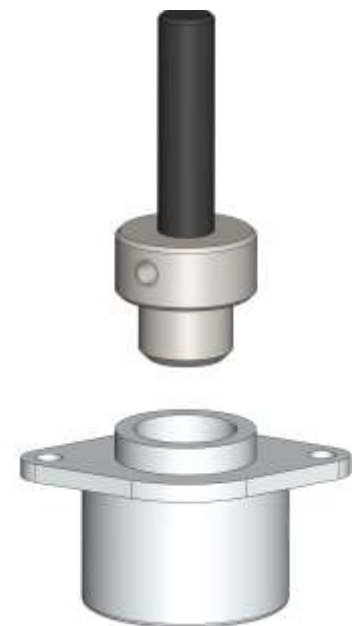

RATED TO
IP68

CE



Available models:

- ☞ **WSM22AS** - Analog single ended Sine Cosine output with a single sine-cosine cycle per rotation
- ☞ **WSM22AC** - Analog complementary Sine Cosine output with a single sine-cosine cycle per rotation
- ☞ **WSM22IR** - Incremental RS422 A, B and Z output with up to 16384 counts per rotation
- ☞ **WSM22SB** - Absolute output on Synchronous Serial interface (SSI) with Binary data up to 13 Bits per rotation
- ☞ **WSM22SG** - Absolute output on Synchronous Serial interface (SSI) with Grey coded data up to 13 Bits per rotation
- ☞ **WSM22BC** - Absolute output on BiSS-C data up to 14 Bits per rotation

Installation drawings:

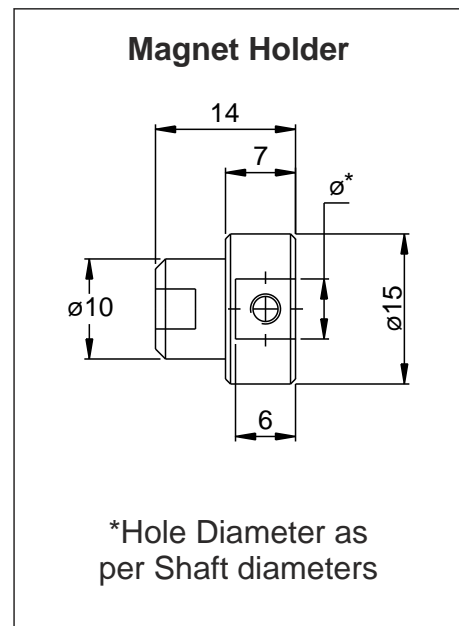
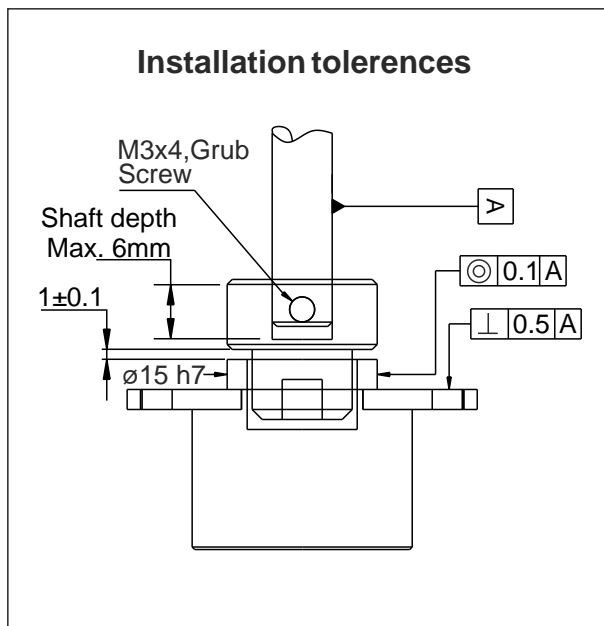
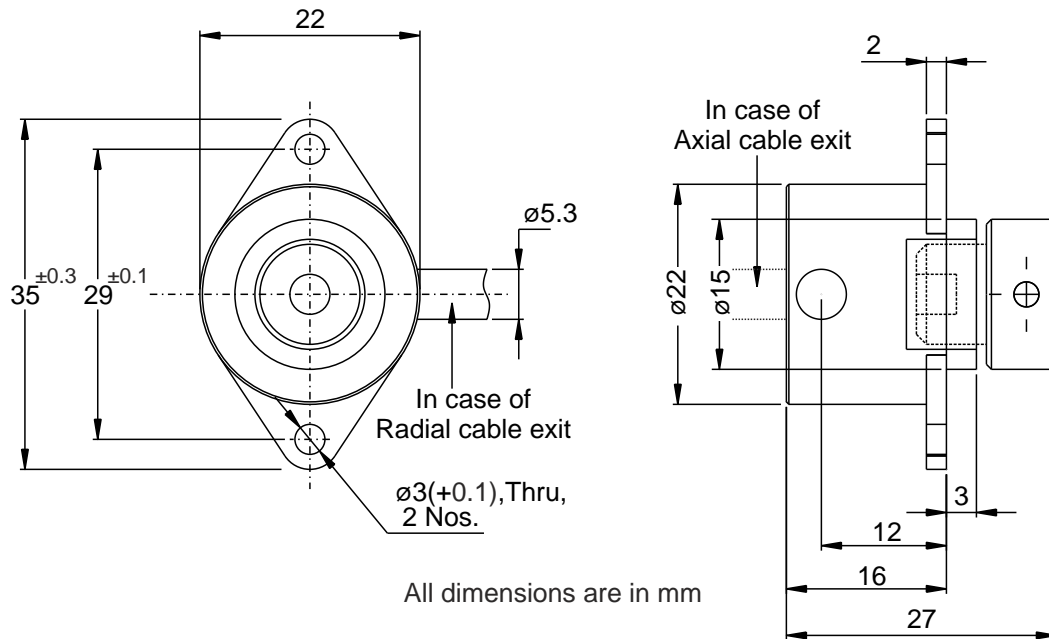

All dimensions are in mm

Cable installation

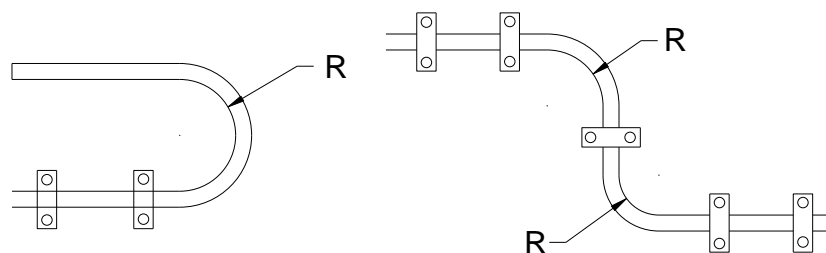

Note: Minimum possible R is 25mm
Tested at 500000 strokes at minimum bending radius

WSM22 Specifications:

	WSM22AS / AC	WSM22IR	WSM22SB / SG	WSM22BC
Power Supply (V_{dd})	+5V DC ($\pm 5\%$)			
Current consumption	50mA maximum		90mA maximum	
Output	AS - 2Vpp each signal AC - 0.5Vpp each signal	RS422		
Maximum RPM	120000 RPM	20000 RPM to 120000 RPM		
Operating Temperature	-40°C to +125°C			
Storage Temperature	-40°C to +125°C			
Storage Humidity	Max. 95% relative humidity (non-condensing)			
Operating Humidity	Max. 80% relative humidity (non-condensing)			
Accuracy	$\pm 0.5^\circ$			
Clock Frequency	Not Applicable		4MHz maximum	10MHz maximum
Output data format	Not Applicable		SB - Binary data SG - Grey coded data	BiSS-C
SSI Data time out	Not Applicable		16 μ S	12.5 μ S to 40 μ S
Standard Cable length	1 m			
Connector type	9 Pin D Connector Male (Plug), Flying leads			
Maximum Cable length	3 m	50 m		
Driving current	20mA max.			
Cable	$\varnothing 5.3$ mm, double shielded PUR cable, dragchain compatible			
Cable exit	Axial, Radial			
Protection class	IP68 (IEC 60529)			
EMI/EMC compliance	EN61326			

Pin Connection details:

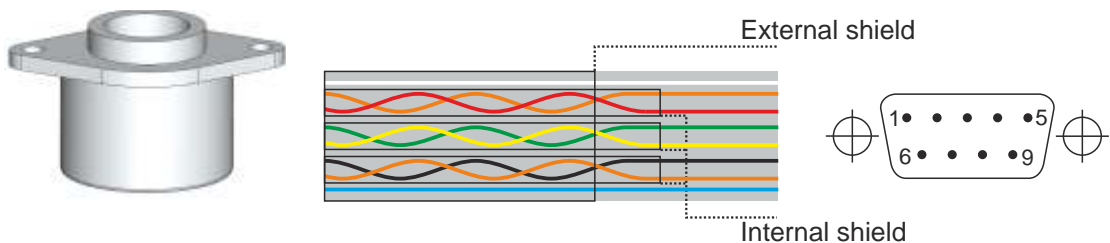

Pin numbers	WSM22AS		WSM22AC		WSM22IR		WSM22SB/SG/BC	
	Signal	Colour	Signal	Colour	Signal	Colour	Signal	Colour
1	Internal Shield		Internal Shield		Internal Shield		Internal Shield	
2	SIN	Red	SIN +	Red	Z +	Brown	CLK +	Red
3	COS	Yellow	COS +	Yellow	B +	Yellow	CLK -	Orange
4	NC	-	NC	-	A +	Red	NC	-
5	Vdd	White	Vdd	White	Vdd	White	Vdd	White
6	NC	-	SIN -	Orange	Z -	Black	Data +	Yellow
7	NC	-	COS -	Green	B -	Green	Data -	Green
8	NC	-	NC	-	A -	Orange	NC	-
9	GND	Blue	GND	Blue	GND	Blue	GND	Blue
Body	External Shield		External Shield		External Shield		External Shield	

Output waveforms:

WSM22AS

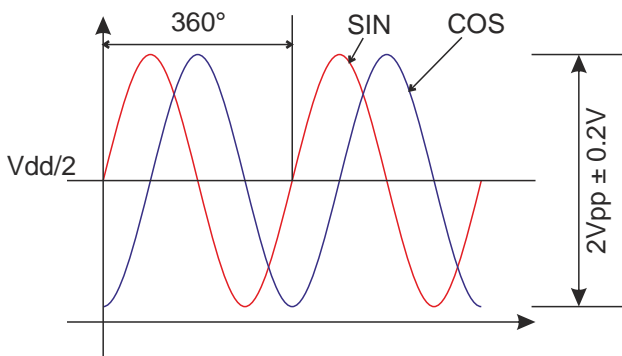

WSM22AC

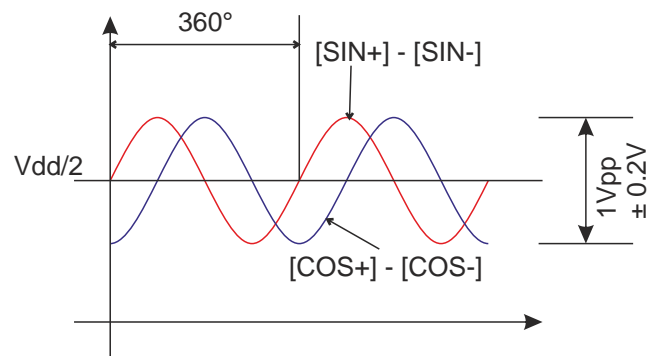

WSM22IR

(Differential signals are not shown)

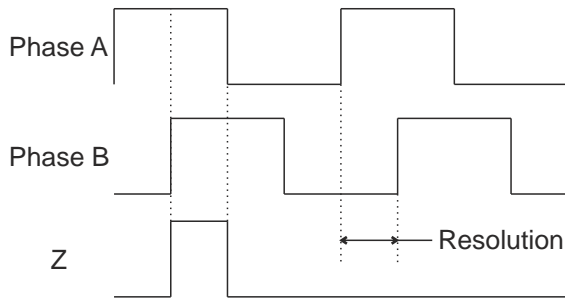

WSM22SB / SG

(Differential signals are not shown)

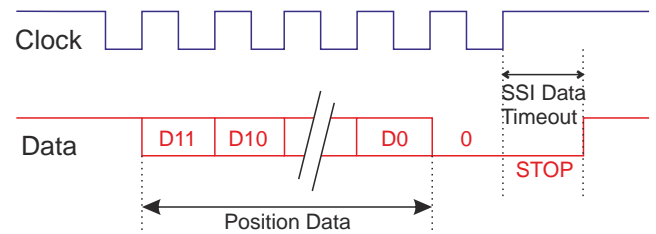

WSM22BC

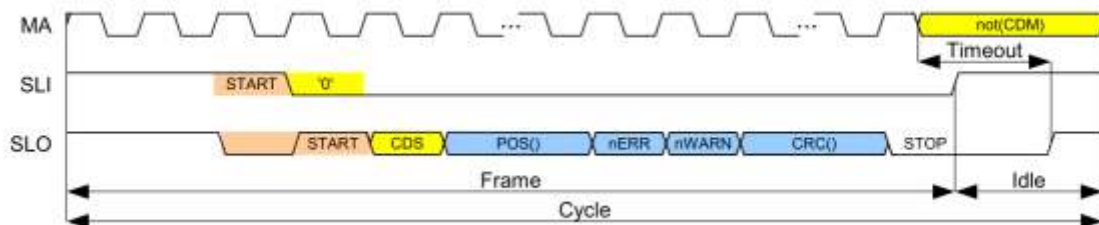

Output Resolutions:

WSM22IR

CPR	Hysteresis	Max. RPM
4 to 256*	0.7°	120000
260 to 512*	0.35°	60000
516 to 4096*	0.17°	30000
8192	0.17°	30000
16384	0.17°	20000

WSM22SB / WSM22SG

No of Bits	Hysteresis
9	0.35°
10 to 13	0.17°

WSM22BC

No of Bits	Hysteresis
8	0.7°
9	0.35°
10 to 14	0.17°

* - In increments of 4. Eg 4, 8, 12, till 256 etc

Note: Pulse per Rotation (PPR) can be calculated as counts per rotation (CPR) ÷ 4

Magnet with Holder:

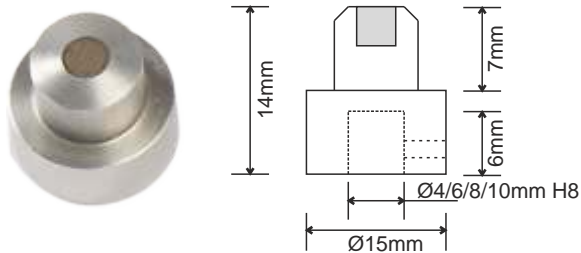

Order code - WSH04 / 06 / 08 / 10

Note: M3 Grub screw is provided on the holder for fixing on to Shaft

Ordering Information:

WSM22

Series name
22mm Circular
rotary modular encoder

Model name
AS - Single ended SIN COS output
AC - Complementary SIN COS output
IR - Incremental RS422 output
SB - SSI with binary data output
SG - SSI with grey coded data output
BC - BiSS-C with binary data output

Resolution in CPR
 For **AS** and **AC**
0000
 For **IR**
0004 to 4096, 8192, 16384
 For **SB** and **SG** (no of bits)
0512(9), 1024(10), 2048(11), 4096(12), 8192(13)
 For **BC** (no of bits)
**0256(8), 0512(9), 1024(10), 2048(11),
 4096(12), 8192(13), 16384(14)**

Cable Length
10 - 1m standard

00 - Standard
RoHS assembly
01 - Standard
non-RoHS assembly

IP Rating
C - IP68

Cable exit type
A - Axial
R - Radial

Connector type
A - Flying leads
B - 9 pin male (plug)
D connector